

CB1775

CANTILEVER BRACKETS

FITTING BRACKET

Wt/100pcs 295 Lbs

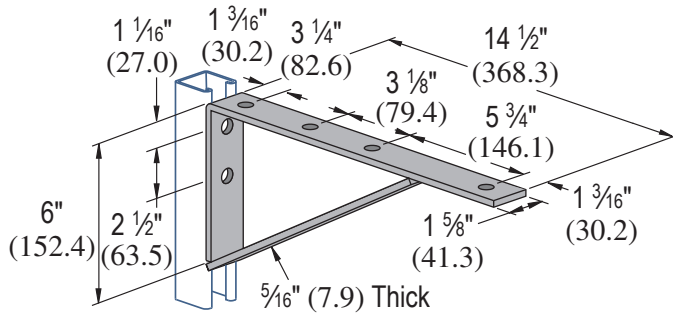

Vertical Channel		Uniform Design Load Lbs
Part No.	Gauge	
CH1000	12	900
CH1100	14	800
CH2000	16	450

Material: 1/4" (6.4) thick steel

Standard Dimensions for 1 1/8" (41.3mm) width series channel fittings (Unless Otherwise Shown on Drawing)

Hole Diameter: 9/16" (14.3mm); Hole Spacing - From End: 13/16" (20.6mm); Hole Spacing - On Center: 1 1/8" (47.6mm); Width: 1 1/8" (41.3mm); Thickness: 1/4" (6.4mm)

Note : When used for mechanical supports, load capacities of brackets and fittings should be in compliance with the American Standard Code for Pressure Piping.

Materials & Finishes: EG

Material Specifications			
Material	Material Code	ASTM Designation	ASTM Description
Steel:	Use Finish Code	ASTM A1011 SS GR 33.	UBS channels are accurately and carefully cold formed to size from low-carbon strip steel. 12 Ga., 14 Ga. & 16 Ga.

Finish Specifications		
Finish	Finish Code	Description
Zinc Electroplated	EG	Zinc electroplating is used to coat plain steel. The electroplating process requires that the component be immersed in a solution containing zinc ions that are deposited on the surface of the part.

PROJECT INFORMATION:		APPROVAL STAMP:
Project:		
Date:	Phone:	
Architect / Engineer:		
Contractor:		
Address:		
Notes 1:		